

Bank Note Paper Mill (BNPM) India Private Limited, Mysore

Invites sealed quotations for providing and supplying, of wooden storage cabinet as per the specification at BNPM at Mysore.

The tender document along with eligibility criteria are hosted on Company's website <http://www.bnpmindia.com>. The tender may be purchased from the Office of Chief General Manager, Bank Note Paper Mill India Private Limited, Administrative office Building, Entry Gate-1, Paper Mill Compound, Note Mudran Nagar, Mysuru - 570 003. Tender may also be downloaded from the above referred website.

The cost of tender document is Rs 1000/- which is non-refundable.

For any query, you may contact at Tel 0821-2401 111, Fax 0821-2581 154



BANK NOTE PAPER MILL INDIA PRIVATE LIMITED
Administrative office building,
Entry Gate.1, Paper mill compound,
Note Mudran Nagar , Mysuru-570 003

BNPM/CO/ENQ/231/2017-18 dated October 04, 2017.

TENDER FOR PROVIDING AND SUPPLYING OF WOODEN STORAGE
CABINET.

Last date for submission of tender: 1200 Hours on 20-10-2017
Opening of Technical Bids: 1215 Hours on 20-10-2017



Index

<u>Section</u>	<u>Description</u>	<u>Page nos.</u>
I.	Notice Inviting Tender	4 to 7
II.	Company/ Firm details	8
III.	Price Bid format	9
IV.	Drawing	10



I. NOTICE INVITING TENDER

Bank Note Paper Mill India Private Limited (BNPM) is a joint venture company between Bharatiya Reserve Bank Note Mudran Private Limited (A wholly owned subsidiary of Reserve Bank of India) and Security Printing and Minting Corporation of India Limited (100% owned by Government of India), incorporated for setting up & manufacturing of bank note papers at Mysore.

1. Sealed tenders are invited by BNPM from eligible & financially sound bidders for providing and supplying of wooden storage cabinet, at BNPM Premises, Note Mudran Nagar, and Mysore - 570003.
2. **Eligibility Criteria:** The prospective bidders should have the following eligibility criteria and should submit the documents as mentioned below.
 - i) The bidder shall be registered company (Proprietorship, Partners or Pvt Ltd etc.)
 - ii) The bidder shall have GST registration.
 - iii) The bidder shall not be black listed by any Govt./Semi Govt./Private Institution. A Self certificate in this regard shall be enclosed.
 - iv) The bidder should have supplier like storage cabinet, partitions, wardrobe etc.,
3. **Cost of Tender Form:** The cost of tender is **Rs 1000/-** and is nonrefundable. The cost of tender shall be paid by Demand draft payable at Mysore in favour of **Bank Note Paper Mill India Private Limited** payable at **Mysore** should be submitted in the envelope containing Earnest Money Deposit (EMD).
4. Tenders should be addressed to The Deputy General Manager, Bank Note Paper Mill India Private Limited and should be submitted on or before **1200 hrs on October 20, 2017** in sealed covers at the office of Bank Note Paper Mill India Private Limited, Administrative office Building, Entry Gate-1, Paper Mill Compound, Note Mudran Nagar, Mysuru - 570 003. Tenders in person may be handed over to DGM. The bid shall be opened at **1215 Hours on October 20, 2017** at the above mentioned address.
5. Tenders should be submitted in a sealed cover, to the offices of the BNPM, super subscribed %Enquiry for providing and supplying of wooden storage cabinet+. The tender shall be submitted as follows
 - a) **Envelope -1 shall contain the following**
 - I. Cost of tender document in the form of DD of Rs 1000/-
 - II. EMD of Rs 3,000/- in the form of DD.
 - III. Technical Deviations, if any.
 - IV. Documentary proof in support for eligibility criteria.



- V. Copy of the blank tender document without any reference to price duly signed on all pages.

b) Envelope -2 shall contain the following

Price Bid as per format enclosed with Tender document.

Both the envelopes shall be put in one envelope and super subscribed **“Enquiry for providing and supplying of wooden storage cabinet”**.

6. Tenders not properly filled, mutilated with incorrect calculations or generally not complying with the conditions may be rejected.
7. Tenderers should quote their prices and rates both in figures and in words. No blank spaces shall be left. All erasures and corrections made while filling up the tender shall be initiated by the tenderer.
8. The tender shall remain open for acceptance for a period of 60 days from the date of opening of the tender.
9. **EVALUATION CRITERIA:**
 - (i) At first stage, techno-commercial bid will be opened and evaluated by the competent committee/ authority with reference to the parameters prescribed in the tender document. Subsequently, in the second stage the financial bids of only technically acceptable offers as decided in first stage shall be opened for further scrutiny and evaluation. Intimation regarding opening of financial bids shall be given to acceptable tenderers to enable them to attend the financial bid opening, if they so desire.
 - (ii) The method of evaluation of bidder for awarding the Contract shall be on schedule wise L-1 bidder and will be decided taking into consideration of the total offered price for delivery up to BNPM, Mysore.
10. Prices quoted should include GST. The rates quoted will be treated as all inclusive and no further claims whatsoever will be entertained in this respect. The quoted rates should be FOR Mysore site basis.
11. The acceptance of the tender will rest with the Owner, who does not bind himself to accept the lowest tender and reserves to himself the authority to reject any or all of the tenders received without assigning any reason thereof.
12. The owner also reserves the right to allot the order partly or wholly to single or different Tenderer.
13. BNPM reserves the right to cancel the tender at any time.
14. **Discrepancy in Prices:**



i) If, in the price structure quoted by a tenderer, there is discrepancy between the unit price and the total price (which is obtained by multiplying the unit price by the quantity), the unit price shall prevail and the total price corrected accordingly, unless BNPM feels that the tenderer has made a mistake in placing the decimal point in the unit price, in which case the total price as quoted shall prevail over the unit price and the unit price corrected accordingly.

ii) If, there is an error in a total price, which has been worked out through addition and/ or subtraction of subtotals, the subtotals shall prevail and the total corrected; and

iii) If, there is a discrepancy between the amount expressed in words and figures, the amount in words shall prevail

iv) If, as per the judgment of BNPM, there is any such arithmetical discrepancy in a tender, the same will be suitably conveyed to the tenderer by registered/speed post. If the tenderer does not agree to the observation of BNPM, the tender is liable to be ignored.

15. **Earnest Money Deposit (EMD):** Interest free EMD of Rs 3,000/- (Rupees Three thousand only). The EMD shall be paid by Demand Draft/ Electronic fund transfer in favour of **Bank Note Paper Mill India Private Limited** payable at **Mysore**. The EMD of unsuccessful bidders shall be returned on finalization of the tender. The EMD of successful bidder shall be returned after completion of warranty period. The tender without EMD shall be liable for rejection. The bank account detail for EMD.

Account Name: Bank Note Paper Mill India Private Limited

Account Name: 05230350002465

IFSC Code : HDFC0000523

Branch: Richmond Road Bangalore

16. Terms of Payment:

- (i) 100% of the bill value shall be paid on completion of works at BNPM Premises and on production of all required documents by the supplier after certification of engineer in charge.

Payments to suppliers shall be made by account payee cheque or through ECS only.

- 16. Time Period:** The time period for providing and supplying of wooden storage cabinet is 30 days from the date of LOI/Purchase Order. Time is the essence of this contract.

- 17. Delivery Terms:** It is responsible of the bidder to arrange transportation and labour required for completion of works on FOR destination basis.

- 18. Delay or Non Delivery:** Time is essence of the contract and completion of delivery dates agreed to are binding on the seller. In the event the seller is not able to supply



as per the delivery schedules given by BNPM, Purchaser will have right either to cancel the order without prejudice to any other rights or to make purchase from an alternate source at the risk and cost of the seller.

In case of rejection and failure to replace goods, the order will be treated as incomplete and we may cancel the order and will arrange to purchase the goods from elsewhere at your risk and cost and the Purchase Order / LOI on you will be cancelled and action taken as per the order terms.

19. **Warranty Period:** The period of warranty for manufacturing defects would be 1 year from the date of supply / completion of works.
20. **Liquidated Damages:** The Employer/Owner shall levy a penalty at the rate of 0.5% for the balance works per week or part thereof of delay in delivery up to a maximum of 10% of the delayed goods.
21. **Tender Evaluation and award of work:** Tenders will be evaluated as per the terms and based on responsiveness taking into account all relevant factors. While the lowest offer will generally be the criteria, BNPM reserves the right to reject any offer including the lowest one if the same is not conforming to its norms. The decision of BNPM in this regard will be final.

All the above terms and conditions have been read, understood and accepted by me.

Authorized Signatory

Name of the Person Signing the Tender _____

Designation _____

Seal with address _____

Address of local office _____



COMPANY/FIRM DETAILS

Registration Details (whichever is applicable and attach copy):

Name of the Tenderer: _____

Address: _____

Tel. No. : _____

Mobile No. : _____

E-mail address: _____

Fax No. : _____

Status of the Company: (Pls. Tick mark as applicable): _____
Proprietor/Partnership/Company

Sl.No.	Description	Registration Under	Copy enclosed Yes / No	Remark
1.	Firm/Company Registration/Individual			
2.	Proof for having registration			
3.	PAN Card No.			
4.	GST Reg. No			
5.	Client list			
6.	Any other additional information			



SCHEDULE OF PRICE – ANNEXURE 1

Price Bids								
SI	Item/ Description	Unit	QTY	Unit Rate	P&F and freight charges	GST @...%	Unit rate incl. P&F, freight and GST	Total Incl. P&F, freight and GST
1	<p>Providing and fixing of storage cabinets formed of 18mm waterproof ply board (green ply, kit ply or equaling - BWP + anti termite resistant as per IS) as per detailed instructions.</p> <p>Shutter of storage to be formed of 18mm waterproof ply board port laminated with 1mm thick laminate to approved shade & colour. All exposed wood edges to be finished with pvc/wood beading / laminate of same colour with neat corner finish etc. as directed. All internal surface to be post laminated with 0.8mm thick laminate to approved shade and colour along with all external exposed wood surfaces. The storage to have all approved hardware with lock and key arrangement etc. complete as directed by engineer in charge.</p> <p>Wooden cabinets shall consist of shelves, shutters with locking arrangements with best practice. These wardrobes are to be fitted & installed on brick wall / concrete wall over floor firmly for storage of lab items under lock and key. The ply board used shall be BWP and anti-termite with 19mm thick of approved makes such as green ply, kit ply, and century ply or equivalent. Laminates shall be 1mm for outer and 0.8mm for internal surfaces of approved make such as sun mica, merino, century or equivalent.</p> <p>a. Hinges shall be made of MS with cathode electrode deposition (CED) or Epoxy coated for better corrosion resistance. The hinges should be spring loaded and should close the doors once left at certain angles.</p> <p>b. Lock & keys shall be of standard quality and of reputed makes for all the cabinets (As per Drawing)</p>	No	04					
	Total- DAP, BNPM, Mysore including all taxes & duties In Rupees (In figures) for Mysore							
	Total- DAP, BNPM, Mysore including all taxes & duties In Rupees (In words) for Mysore							



SIGNATURE OF THE TENDERER

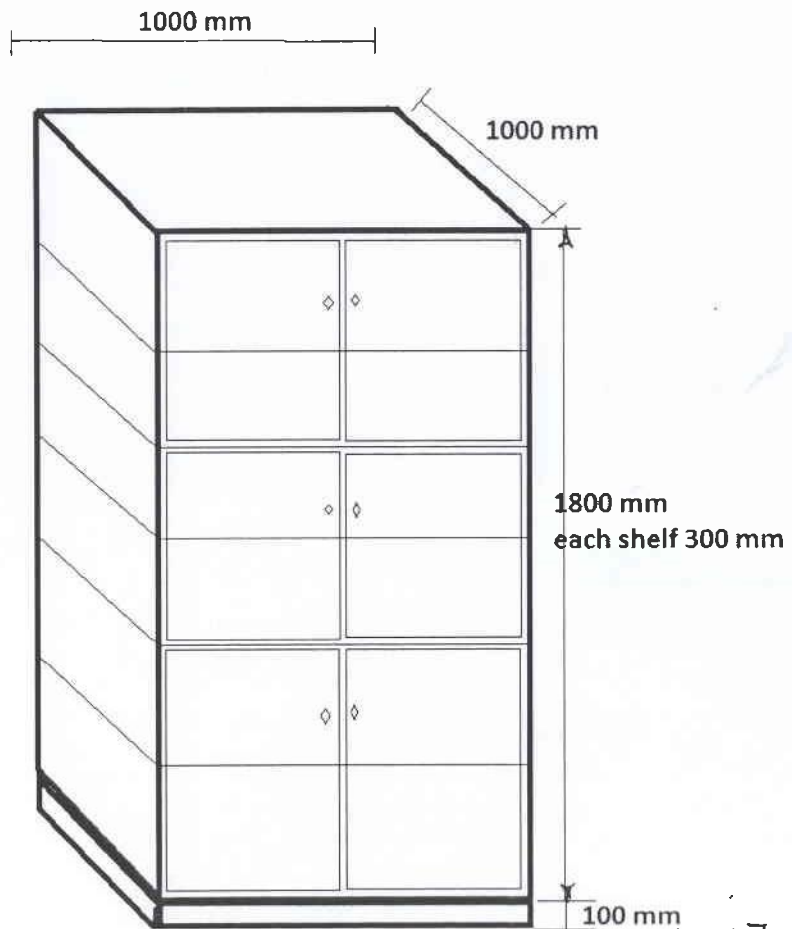

wooden storage cabinets [Sketch of 01 Unit]

